

Wire electrodes for wire electric discharge machining

CT-Wire

TH Series Hard wire

(a compound product consisting of 60% Cu and 40% Zn)

In order to meet the demand for high precision wire electrodes driven by ultra-high precision and processing speed of wire electric discharge machines, we offer high quality, high performance TH series products with a wide range of wire diameters and bobbin sizes at appropriate delivery time and price.

TH wire characteristics

To support various types and thickness of processing metals, these wire electrodes are manufactured from JIS C2800 type brass according to our standard hardness specifications.



High dimensional accuracy

The product is manufactured with outer dimension accuracy (wire diameter tolerance) of ± 0.001 , and roundness within 0.001mm.

Excellent straightness

We strictly perform the test for the number of curls and waves using our original measurement method.

Stable mechanical characteristics

Manufactured on the latest equipment with required elongation and maximal tensile strength, ensuring stable quality with low variations. Products are subjected to strict inspections in automatic measuring systems.

In order to stabilize high performance of electrode wires, we use diamond drawing dies, lubricating liquid and other original control methods. Drawing is always performed in the best conditions, and the surface is finished without irregularities, dirt and scratches.

Product specifications

Material	Code	Nominal wire diameter [mm]	Tensile strength [N/mm ²] {kgf2/mm ² }	Elongation [%]	Wire diameter tolerance [mm]	Roundness [mm]
JIS C2800W	H	0.10, 0.15, 0.20 0.25, 0.30	Min. 980 {100} Min 930 {95}	Min. 0.4	± 0.001	Within 0.001

Line-up

Wire diameter	Bobbin (net weight)								
	P3 (3kg)	P5 (3) (3kg)	P5 (5kg)	P10 (10kg)	P15 (15kg)	P20 (20kg)	DP30 (30kg)	D160 (6.8kg)	D200 (15kg)
0.10	○	○	—	—	—	—	—	—	—
0.15	○	○	—	—	—	—	—	—	—
0.20	○	—	○	○	○	○	○	○	○
0.25	○	—	○	○	○	○	○	○	○
0.30	○	—	○	○	○	○	○	○	○

Bobbin shape (unit: mm)

Product name	D Flange diameter	d ₁ Barrel diameter	L Outer width	W Inner width	d ₂ Shaft hole diameter
P3	130	80	110	90	20
P5	160	90	114	90	20
P10, P15	200	90	134	110	25
P20	250	110	140	110	34
DP30	280	200	220	180	73
D160	160	100	160	128	22
D200	200	125	200	160	22

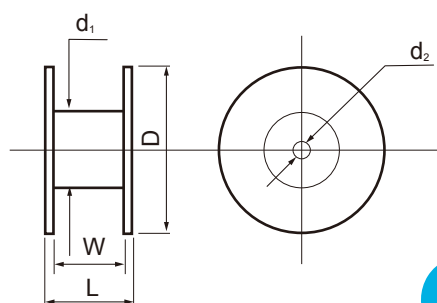

*Please contact the distributor for bobbin shapes not mentioned in this table.

Product list

Wire diameter	Non-paraffin products		Paraffin products		Weight (quantity)
	Product code	Product name	Product code	Product name	
Φ0.10	1027111	CTW-10TH-P3	1022111	CTW-10TH-P3S	3kg reel (6 pcs.)
Φ0.15	1027112	CTW-15TH-P3	1022112	CTW-15TH-P3S	
Φ0.20	1027113	CTW-20TH-P3	1022113	CTW-20TH-P3S	
Φ0.25	1027114	CTW-25TH-P3	1022114	CTW-25TH-P3S	
Φ0.30	1027115	CTW-30TH-P3	1022115	CTW-30TH-P3S	
Φ0.10	1027211	CTW-10TH-P5 (3)	1022211	CTW-10TH-P5 (3) S	3kg reel on 5 kg bobbin (4 pcs.)
Φ0.15	1027212	CTW-15TH-P5 (3)	1022212	CTW-15TH-P5 (3) S	
Φ0.20	1027233	CTW-20TH-P5	1022233	CTW-20TH-P5S	5kg reel (4 pcs.)
Φ0.25	1027234	CTW-25TH-P5	1022234	CTW-25TH-P5S	
Φ0.30	1027235	CTW-30TH-P5	1022235	CTW-30TH-P5S	
Φ0.20	1027323	CTW-20TH-P10	1022323	CTW-20TH-P10S	10kg reel (2 pcs.)
Φ0.25	1027324	CTW-25TH-P10	1022324	CTW-25TH-P10S	
Φ0.30	1027325	CTW-30TH-P10	1022325	CTW-30TH-P10S	
Φ0.20	1027373	CTW-20TH-P15	1022373	CTW-20TH-P15S	15kg reel (2 pcs.)
Φ0.25	1027374	CTW-25TH-P15	1022374	CTW-25TH-P15S	
Φ0.30	1027375	CTW-30TH-P15	1022375	CTW-30TH-P15S	
Φ0.20	1027463	CTW-20TH-P20	1022463	CTW-20TH-P20S	20kg reel (1 pc.)
Φ0.25	1027464	CTW-25TH-P20	1022464	CTW-25TH-P20S	
Φ0.30	1027465	CTW-30TH-P20	1022465	CTW-30TH-P20S	
Φ0.20	1027683	CTW-20TH-DP30	1022683	CTW-20TH-DP30S	30kg reel (1 pc.)
Φ0.25	1027684	CTW-25TH-DP30	1022684	CTW-25TH-DP30S	
Φ0.30	1027685	CTW-30TH-DP30	1022685	CTW-30TH-DP30S	
Φ0.20	1027743	CTW-20TH-D160 (6)	1022743	CTW-20TH-D160 (6) S	6kg reel (2 pcs.)
Φ0.25	1027744	CTW-25TH-D160 (6)	1022744	CTW-25TH-D160 (6) S	
Φ0.30	1027745	CTW-30TH-D160 (6)	1022745	CTW-30TH-D160 (6) S	
Φ0.20	1027753	CTW-20TH-D160 (8)	1022753	CTW-20TH-D160 (8) S	8kg reel (2 pcs.)
Φ0.25	1027754	CTW-25TH-D160 (8)	1022754	CTW-25TH-D160 (8) S	
Φ0.30	1027755	CTW-30TH-D160 (8)	1022755	CTW-30TH-D160 (8) S	
Φ0.20	1027873	CTW-20TH-D200 (15)	1022873	CTW-20TH-D200 (15) S	15kg reel (1 pc.)
Φ0.25	1027874	CTW-25TH-D200 (15)	1022874	CTW-25TH-D200 (15) S	
Φ0.30	1027875	CTW-30TH-D200 (15)	1022875	CTW-30TH-D200 (15) S	

*Please contact the distributor for wire diameters, weights and bobbin sizes not mentioned in this table.



Chiba Techno Co.,Ltd.

■ **Head office** Klingelnberg bldg 2F, Shin-Yokohama 1-13-12,
Kouhoku-ku, Yokohama-shi, Kanagawa, 222-0033
TEL : +81-45-473-9933 FAX : +81-45-473-9729

■ **Yuzawa Factory** Nakawara 116-7,
Fukabori, Yuzawa-shi, Akita, 012-0051
TEL : +81-183-73-0106 FAX : +81-183-73-0199

<https://chb.co.jp/en/>

Distributor