

RGH-Type

(RoHS指令対応品)

■特性 Characteristics

試験項目 Test items	試験方法 Test method	規格値 Specified value
抵抗温度特性 Resistance temperature charact	常温~125℃	<20Ω : ±400ppm/℃ ≥20Ω : ±260ppm/℃
短時間過負荷 Short-time overload	定格電力×10倍 5秒間	±(2%+0.05Ω)
絶縁抵抗 Insulation resistance	D C500V メガー	20MΩ以上
耐電圧 Withstanding voltage	単品 A C2000V O S付、O付 A C3000V	±(0.1%+0.05Ω) ブレークダウンなし
端子強度 Terminal strength	44N 30秒間	機械的損傷なし
耐湿負荷寿命 Moisture load life	40℃ 90~95% 定格電力×1/10 500H r	±(3%+0.05Ω)
定格負荷 Rated load	定格電圧 30分間	350℃以下 ±(0.5%+0.05Ω)
負荷寿命 Load life	定格電力 500H r 1.5H r. ON-0.5H r. OFF	±(5%+0.05Ω)
耐熱性 Heat resistance	350℃ 2時間	機械的損傷なし
熱衝撃 Thermal shock	定格電力 30分後 -55℃ 15分間	±(2%+0.05Ω)

■製品紹介 Introduction

本抵抗器はJIS-C-6401に準拠して製作したもので厳選された抵抗線を巻線した後に特殊不燃性塗料にてコーティングを施したものです。過負荷に対して発煙は極めて少なく、発火及び熔融の危険はありません。

■特徴 Features

1. 広い電力範囲・・・5W~1KWまで18種あり、電力型タイプの基本抵抗器です。
2. 過負荷安全性・・・従来のホーロー抵抗に比較し、過負荷時の発火、熔融がなく、安全性が確保されています。

■品番構成法 Type descriptions

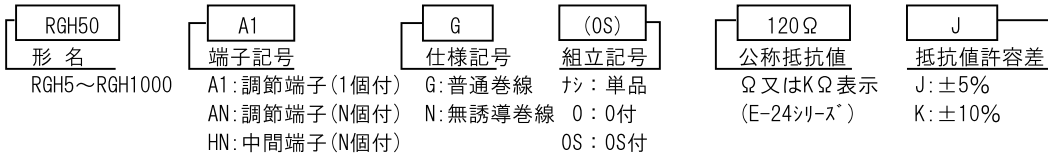

(注1)A1以外は全てカスタム品となります。お問い合わせください。

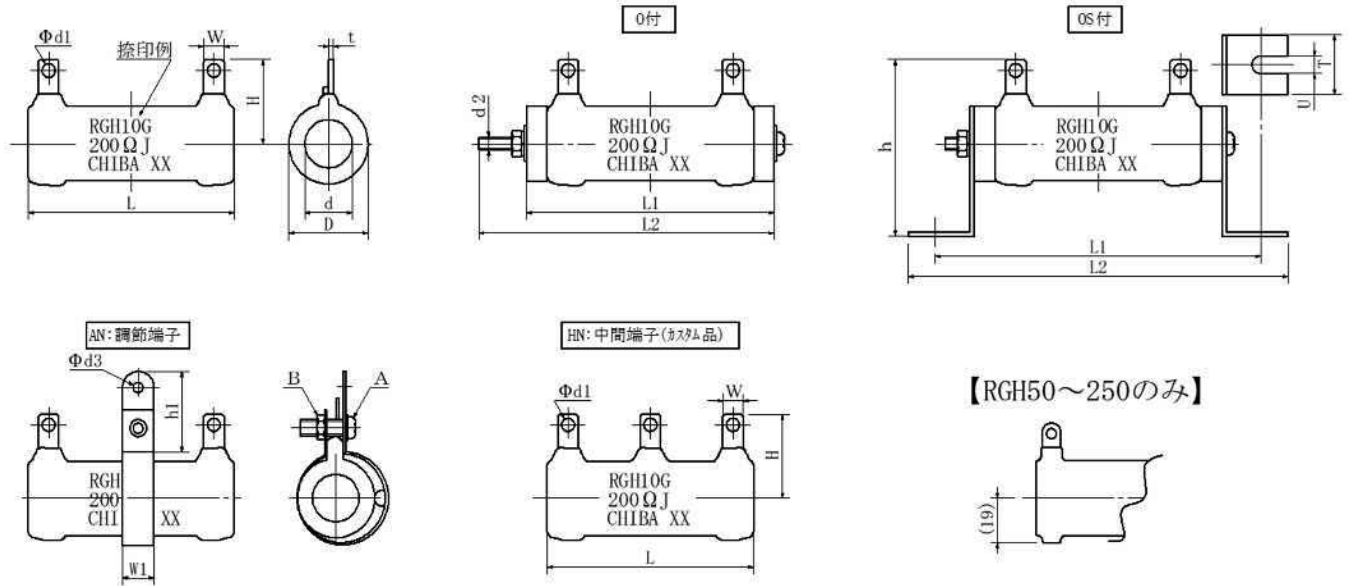

■負荷軽減曲線 Load derating curve

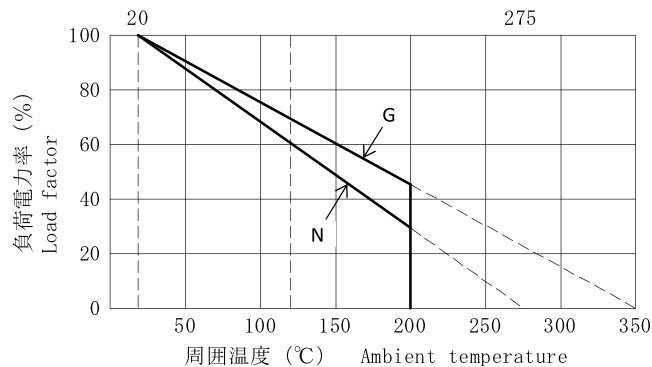

■温度上昇曲線 Temperature rise curve (参考)

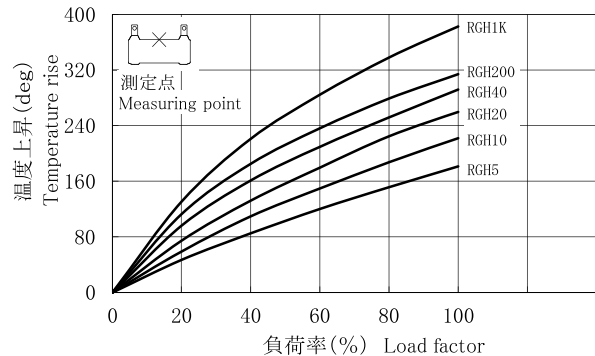

不燃性塗料巻線固定抵抗器 Flame Proof Wire Wound Fixed Resistors

■寸法及び抵抗値範囲 Dimensions & Resistance range

形名 Style	定格電力(W) Power rating		抵抗値範囲(Ω) Resistance range			寸法(mm) Dimensions							
	普通巻	無誘導	普通巻(注1)	無誘導巻(注2)	調節端子	L	D	H	d	W ±0.5	d1	t	d2
RGH5	5	3	0.10~ 3.9K	0.10~ 1.8K	0.10~ 270	30±1.2	15MAX	17.5±1.5	6.0 ⁺¹ ₋₂	5	3.2±0.3	1.0	M3
RGH10	10	5	0.12~ 6.8K	0.12~ 4.7K	0.12~ 560	45±1.2	"	"	"	"	"	"	"
RGH20	20	10	0.22~ 15.0K	0.22~ 8.2K	0.22~ 1.0K	50±1.2	22MAX	21.0±1.5	11.5 ⁺¹ ₋₂	"	"	"	"
RGH30	30	15	0.33~ 22.0K	0.33~15.0K	0.33~ 1.5K	75±1.5	"	"	"	"	"	"	"
RGH40	40	20	0.39~ 27.0K	0.39~18.0K	0.39~ 2.4K	90±1.5	"	"	"	"	"	"	"
RGH50	50	22	"	0.39~18.0K	0.39~ 2.7K	75±1.5	32MAX	32.0±1.5	16.0 ⁺¹ ₋₂	8	4.5±0.3	1.6	M4
RGH60	60	25	0.56~ 43.0K	0.56~22.0K	0.56~ 3.3K	90±1.5	"	"	"	"	"	"	"
RGH80	80	35	0.68~ 56.0K	0.68~33.0K	0.68~ 4.7K	115±1.5	"	"	"	"	"	"	"
RGH100	100	43	1.00~ 62.0K	1.00~39.0K	1.00~ 5.6K	140±2.0	"	"	"	"	"	"	"
RGH120	120	50	1.20~ 82.0K	1.20~47.0K	1.20~ 6.8K	165±2.0	"	"	"	"	"	"	"
RGH150	150	66	1.50~ 82.0K	1.50~56.0K	1.50~ 7.5K	195±2.0	"	"	"	"	"	"	"
RGH200	200	88	2.20~100.0K	2.20~82.0K	2.20~ 9.1K	254±2.0	"	"	"	"	"	"	"
RGH250	250	108	3.30~100.0K	3.30~82.0K	3.30~10.0K	305±2.0	"	"	"	"	"	"	"
RGH300	300	130	4.70~100.0K	4.70~82.0K	4.70~10.0K	254±2.0	46MAX	44.0±3.0	25.0 ±1.5	13	6.0±0.5	2.0	—
RGH400	400	168	"	"	"	330±2.0	"	"	"	"	"	"	—
RGH500	500	210	10.00~100.0K	10.00~82.0K	10.00~10.0K	300±2.0	57MAX	49.0±3.0	30.0 ±1.5	"	"	"	—
RGH750	750	315	"	"	—	300±2.0	82MAX	62.0±3.0	50.0 ±1.5	"	"	"	—
RGH1000	1000	420	"	"	—	300±2.0	110MAX	75.0±3.0	70.0 ±1.5	"	"	"	—

形名 Style	寸法(mm) Dimensions			O(注4)		OS		調節端子(注5)			ヒース	ナット	重量(g) Weight (注3)
	h	U	T	L1	L2 +0 -1.5	L1	L2	W1 ±0.5	d3 ±0.3	h1 ±1	A	B	
RGH5	29.5±3	3.5±0.3	12±0.3	38±1.5	50	48±1.5	58±1.5	6	2.8	15	M3*10	1種	7
RGH10	"	"	"	53±1.5	65	63±1.5	73±1.5	"	"	"	"	"	11
RGH20	36.0±3	4.5±0.3	18±0.3	60±1.5	70	74±1.5	86±1.5	"	3.2	"	M3*12	"	24
RGH30	"	"	"	85±2.0	95	99±2.0	111±2.0	"	"	"	"	"	37
RGH40	"	"	"	100±2.0	110	114±2.0	126±2.0	"	"	"	"	"	40
RGH50	57.0±3	6.0±0.3	27±0.4	87±2.0	100	103±2.0	125±2.0	8	4.2	16	M3*15	"	71
RGH60	"	"	"	102±2.0	115	118±2.0	140±2.0	"	"	"	"	"	90
RGH80	"	"	"	127±2.0	140	143±2.0	165±2.0	"	"	"	"	"	110
RGH100	"	"	"	152±2.5	165	168±2.5	190±2.5	"	"	"	"	"	125
RGH120	"	"	"	177±2.5	190	193±2.5	215±2.5	"	"	"	"	"	150
RGH150	"	"	"	207±2.5	220	223±2.5	245±2.5	"	"	"	"	"	190
RGH200	"	"	"	266±2.5	280	282±2.5	304±2.5	"	"	"	"	"	250
RGH250	"	"	"	317±2.5	330	333±2.5	355±2.5	"	"	"	"	"	300
RGH300	84.0±4	10.0±0.5	40±0.5	—	—	304±3.0	334±3.0	11	4.3	20	M4*20	"	530
RGH400	"	"	"	—	—	380±3.0	410±3.0	"	"	"	"	"	630
RGH500	99.0±5	"	58±0.5	—	—	350±3.0	380±3.0	"	4.5	25	"	"	1000
RGH750	112.0±5	"	"	—	—	358±3.0	388±3.0	—	—	—	—	—	1500
RGH1000	160.0±5	8.5±0.5	100±1.0	—	—	389±3.0	440±3.0	—	—	—	—	—	3100

(注1) 普通巻品は10Ω未満の場合、J(±5%)対応が不可能の場合があります。

(注2) 無誘導巻品での抵抗値許容差はお問い合わせください。

(注3) 重量は組立無しの場合。

(注4) RGH300以上のO付は未対応になります。

(注5) 無誘導巻の調節端子付は未対応になります。